



Digital electro-pneumatic positioner for integrated mounting on process control valves

- Compact and robust stainless steel design
- Easy start-up with automatic X-Tune function
- Contact-free position sensor
- Integrated pilot air duct with spring chamber aeration
- EtherNet/IP, PROFINET, Modbus TCP, PROFIBUS DP-V1 or Bürkert system bus (büS)

Product variants described in the data sheet may differ from the product presentation and description.

Can be combined with

	Type 2301 ▶ Pneumatically operated 2-way Globe Control Valve
	Type 2300 ▶ Pneumatically operated 2-way angle seat control valve ELEMENT
	Type 2103 ▶ 2/2-way diaphragm valve with pneumatic stainless steel actuator (Type ELEMENT) for decentralised automation
	Hygienic process valves

Type description

The compact positioner device key 8692 is optimised for integrated mounting on the pneumatic actuators in the process valve series Type 23xx/2103 and is specially designed for the requirements of a hygienic process environment. The pilot air duct is integrated into the actuator without external piping. The easy operation and the selection of additional software functions are carried out either on a big graphic display with backlight and keypad or via the COMMUNICATOR.

The positioner registers the valve position without deterioration via a contact-free, analogue position sensor. The integrated diagnostics function are used to monitor control valve operating conditions. Valve diagnostic messages via status signals are issued in accordance with NE107 (NAMUR) and recorded as historical entries.

The housing is easy to clean and features proven IP protection and chemically resistant materials for use in hygienic processing in the food, beverage and pharmaceutical industries. Combined with Bürkert ELEMENT actuators, the pneumatic actuating system enables spring chamber aeration that avoids actuator chamber contamination from the environment.

Table of contents

1. General technical data	3
2. Materials	5
2.1. Material specifications	5
3. Dimensions	6
3.1. Multipole version.....	6
3.2. Cable gland version	6
3.3. Mounting on control valves of actuator series Type 23xx, actuator size 70/90/130 mm.....	7
3.4. Mounting on control valves of actuator series Type 27xx , actuator size 175/225 mm.....	7
4. Device/Process connections	8
4.1. Electrical connections.....	8
Multipole connection.....	8
Cable gland.....	8
PROFIBUS DP connection.....	9
EtherNet/IP-, PROFINET-, Modbus TCP connection.....	10
Bürkert system bus (büS) connection.....	10
5. Performance specifications	11
5.1. Signal flow diagram.....	11
Position control loop	11
Additional software options of the TopControl Type 8692 (extract).....	11
5.2. Interface diagram	12
Version without fieldbus communication	12
Version with fieldbus communication	12
6. Product installation	13
6.1. Combination options with pneumatic process valves	13
7. Ordering information	14
7.1. Bürkert eShop – Easy ordering and quick delivery.....	14
7.2. Bürkert product filter	14
7.3. Ordering chart.....	15
7.4. Ordering chart accessories.....	16
Standard Accessories.....	16
Adapter kits.....	16

1. General technical data

Product properties	
Dimensions	Detailed information can be found in chapter "3. Dimensions" on page 6.
Material	
Housing	PPS, stainless steel
Seal	EPDM
Cover	PC
Operation	
Display	Graphic display with backlighting and intuitive menu navigation
Operating keys	Membrane keypad with 4 keys
Service interface	Connected to PC via USB connection
Configuration tool	Bürkert Communicator PACTware (only for device versions with PROFIBUS, resp. analogue version with serial interface)
Commissioning	
Initialization positioner	Automatic by X.TUNE function (automatic adjustment of the positioner)
Manual operation of pilot valve	In manual mode via push-button on control panel
Status display	
Display of device and valve status	LEDs (colours acc. to NAMUR); only for Ethernet and bÜS versions)
Communication	
Fieldbus	EtherNet/IP, PROFINET, Modbus TCP, PROFIBUS DP-V1
Digital	Bürkert system bus (bÜS) - based on CANopen
Performance data	
Position sensor	
Measuring principle	Inductive
Position detection module	Contactless (wear-free) analogue position sensor
Stroke range	
Valve spindle	3...45 mm
Electrical data	
Operating voltage	24 V DC \pm 10 % UL: NEC Class 2
Residual ripple	Max.10 %
Power consumption	< 5 W
Protection class	3 acc. to DIN EN 61140 (VDE 0140-1)
Input /Output	
Digital input	1 binary input, 0...5 V = log "0", 10...30 V = log "1"
Digital output	2 binary output (optional), galvanically isolated
Current limitation	100 mA, output will be synchronised when overloaded
Analogue output	1 output (optional) 0/4...20 mA, 0...5/10 V
Input data setpoint	
Setpoint signal	
Setpoint setting	0/4...20 mA and 0...5/10 V
Input resistance	0/4...20 mA: 180 Ω 0...5/10 V: 19 k Ω
Electrical connection	
Multipole version	M12, 8-pin resp. 4 or 5-pin acc. to device version (see "4. Device/Process connections" on page 8)
Cable gland version	2xM16 \times 1.5 (cable \varnothing 5...10 mm) with terminals for cable cross-sections 0.14...1.5 mm ²

Pneumatic data	
Control medium	Neutral gases, air, quality class acc. to ISO 8573-1
Dust content	Class 7 (< 40 µm particle size)
Particle density	Class 5 (< 10 mg/m ³)
Pressure dew point	Class 3 (< -20 °C)
Oil content	Class X (< 25 mg/m ³)
Air supply filter	Exchangeable
Mesh size	~0.1 mm
Supply pressure	
Low air capacity	0...7 bar ^{1.)}
High air capacity	3...7 bar
Pilot air port	Threaded port G 1/8, stainless steel
Positioning system	
Low air capacity	
Single and double acting	7 l _N /min for aeration and ventilation (Q _{Nn} value acc. to definition at pressure drop from 7 to 6 bar absolute)
Actuator series/size	Type 23xx, Ø actuator 70/90 mm
High air capacity	
Single acting	130 l _N /min for aeration and ventilation (Q _{Nn} value acc. to definition at pressure drop from 7 to 6 bar absolute)
Actuator series/size	Type 23xx, Ø actuator 70/90 mm Type 27xx, Ø actuator 175/225 mm
Approvals and certificates	
Conformity	EMC directive 2014/30/EU
Ignition protection	II 3D Ex tc IIIC T135 °C Dc II 3G Ex ec IIC T4 Gc
UL	cULus certificate: E238179
ATEX	II 3D Ex tc IIIC T135 °C Dc II 3G Ex ec IIC T4 Gc Certificate: BVS 14 ATEX E 008 X
IECEX	Ex tc IIIC T135 °C Dc Ex ec IIC T4 Gc Certificate: IECEX BVS 14.0009 X
CCC (China Compulsory Certificate)	For devices with Ex approval
Environment and installation	
Operating conditions	
Ambient temperature (max.)	-10...+55 °C
Degree of protection	IP65/IP67 acc. to EN 60529, 4X acc. to NEMA 250 Standard
Operating altitude	Up to 2000 m above sea level
Installation and mechanical data	
Installation position	As required, preferably with actuator in upright position
Valve actuator (type, size)	ELEMENT Type 23xx (actuator size Ø70/90/130 mm) CLASSIC Type 27xx (actuator size Ø175/225 mm)
Adapter kit	Detailed information can be found in chapter "Adapter kits" on page 16.

1.) The supply pressure applied must be 0.5 to 1 bar above the minimum required pilot pressure of the valve actuator.

2. Materials

2.1. Material specifications

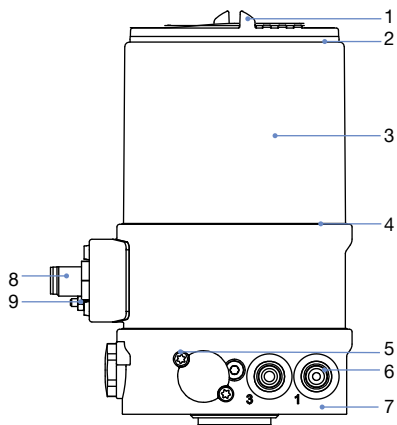

No.	Element	Material
1	Cover	PC
2	Seal	EPDM
3	Outer casing	Stainless steel
4	Seal	EPDM
5	Screws	Stainless steel
6	Push-in connector Threaded port G 1/8	POM/Stainless steel Stainless steel
7	Basic housing	PPS
8	M12 plug connector	Stainless steel
9	Screws	Stainless steel

3. Dimensions

3.1. Multipole version

Note:

Dimensions in mm

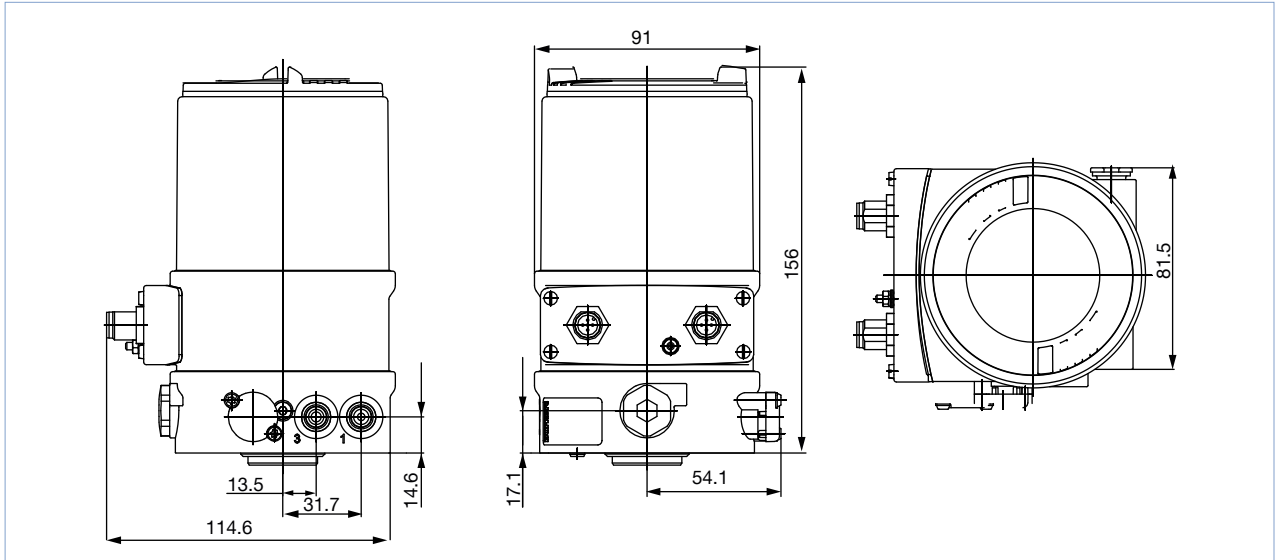

3.2. Cable gland version

Note:

Dimensions in mm

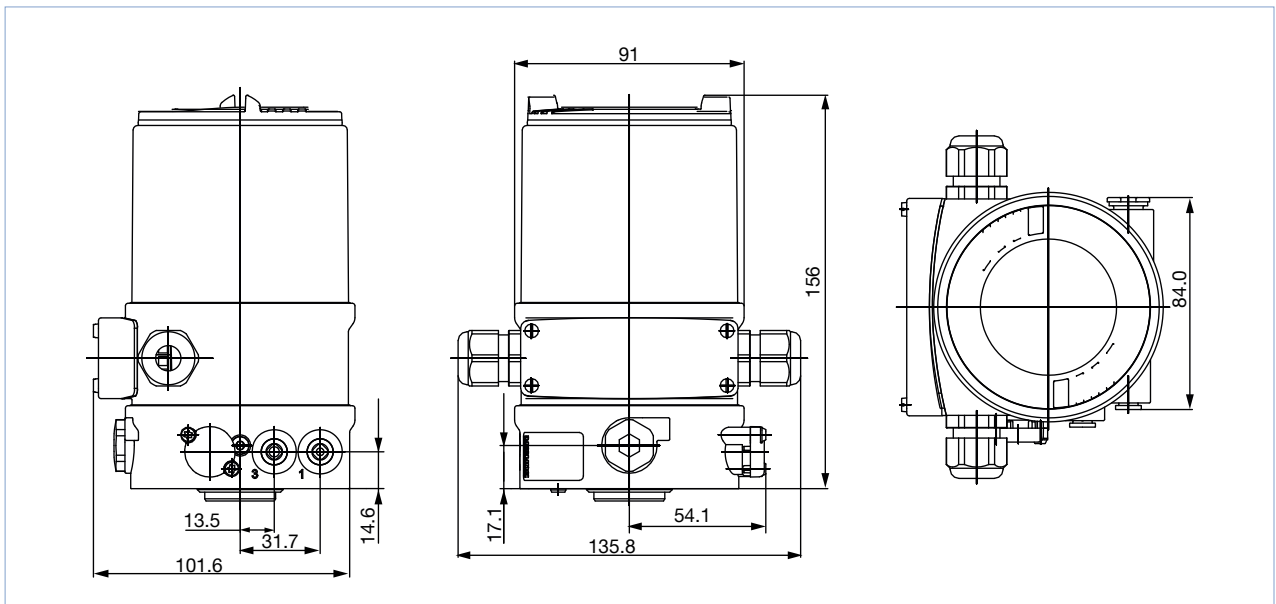

3.3. Mounting on control valves of actuator series Type 23xx, actuator size 70/90/130 mm

Note:

Dimensions in mm

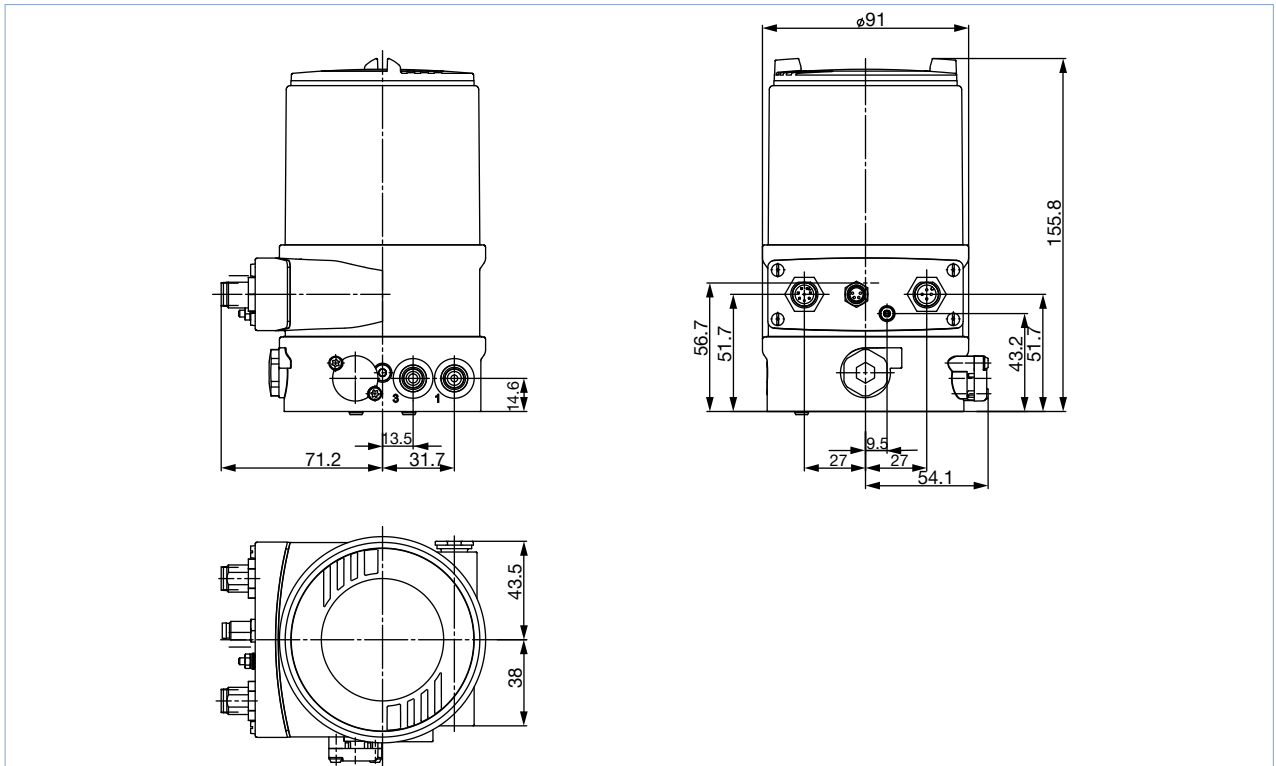

3.4. Mounting on control valves of actuator series Type 27xx, actuator size 175/225 mm

Note:

Dimensions in mm

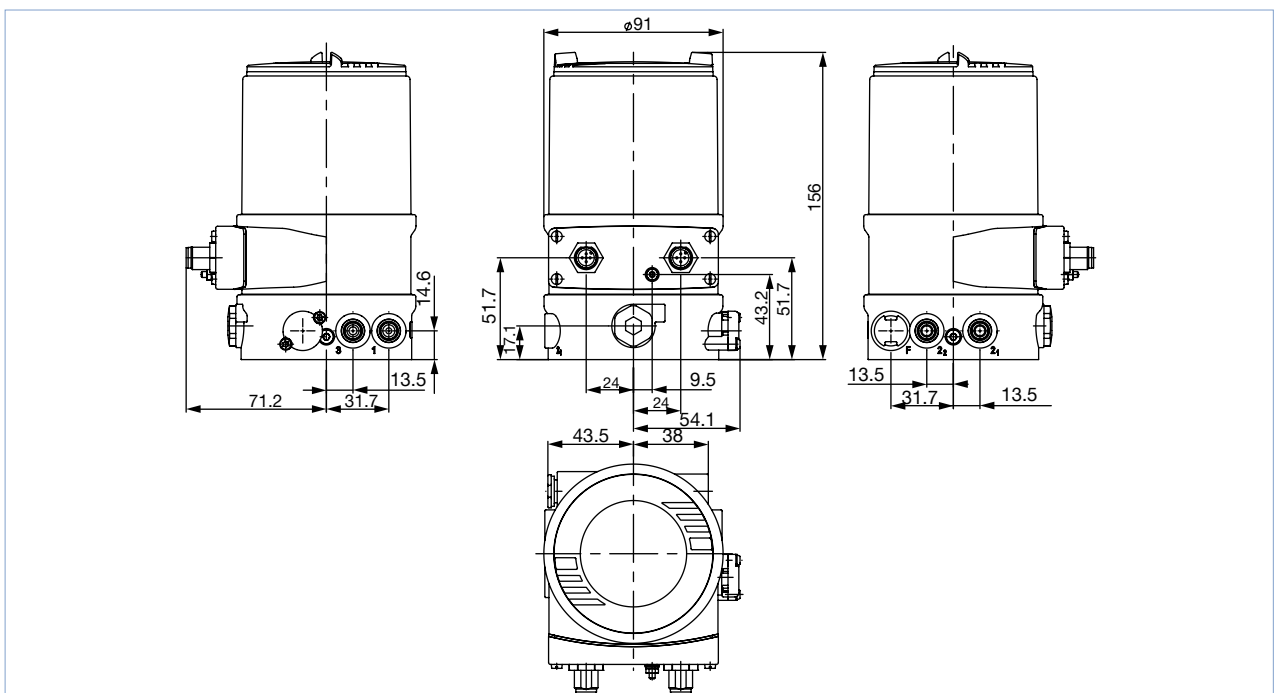

4. Device/Process connections

4.1. Electrical connections

Multipole connection

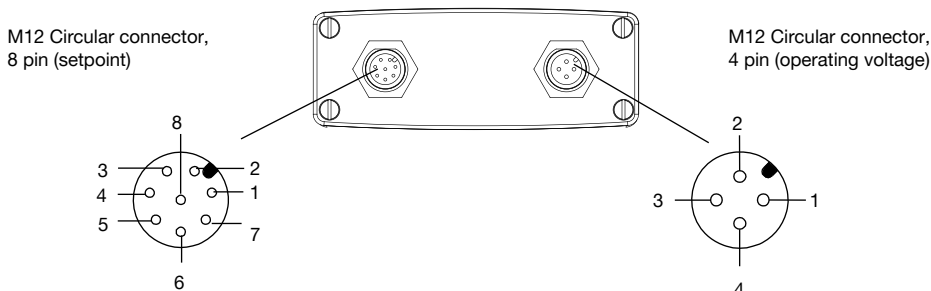

M12 circular plug, 8-pin
(setpoint)

Pin	Pin assignment
8	Setpoint + (0/4...20 mA/0...5/10 V)
7	Setpoint GND

M12 circular plug, 8-pin
(in/output signal)^{1.)}

Pin	Pin assignment
6	Analogue feedback +
5	Analogue feedback GND
4	Digital output 1
3	Digital output 2
2	Digital output GND
1	Digital input +

M12 circular plug, 4-pin
(operating voltage)

Pin	Pin assignment
1	Operating voltage +24 V DC
3	Operating voltage GND

1.) With the option analogue feedback or binary output

Cable gland

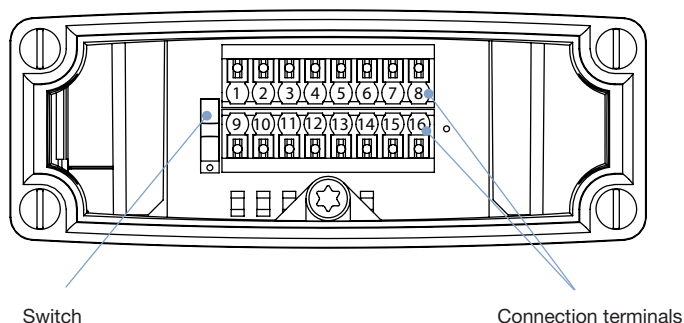

Terminal	Pin assignment
1	Analogue feedback GND
2	Analogue feedback +
3	Digital output GND
4	Digital output 2
5	Digital output 1
6	Digital input +
7	Setpoint GND
8	Setpoint +
9	Not assigned
10	Not assigned
11	Not assigned
12	Not assigned
13	Not assigned
14	Digital input GND
15	Operating voltage GND
16	Operating voltage +24 V

PROFIBUS DP connection

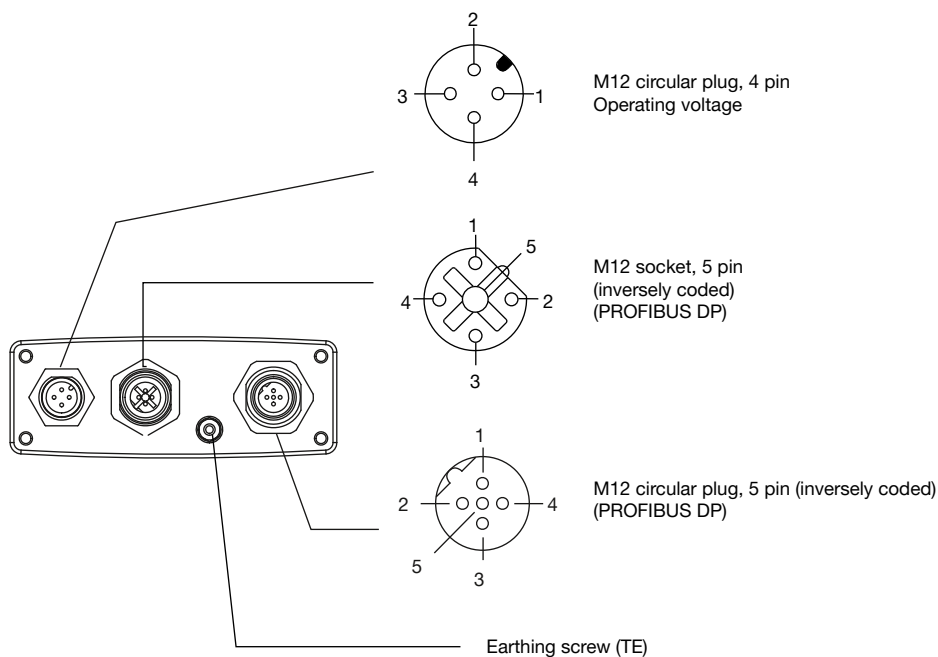

Socket/M12 circular plug, 5-pin - fieldbus connection

Pin	Pin assignment
1	VP+5
2	RxD/TxD-N
3	DGND
4	RxD/TxD-P
5	Not assigned
Thread	Shielding/protective earth

M12 circular plug, 4-pin - operating voltage

Pin	Wire colour ^{1.)}	Pin assignment
1	Brown	+24 V
3	Blue	GND

1.) The wire colours indicated refer to the connection cable available as an accessory with the Article no. 918038.

EtherNet/IP-, PROFINET-, Modbus TCP connection

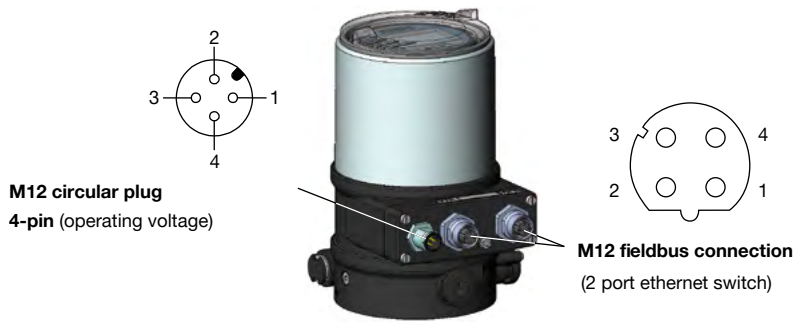

M12 fieldbus connection, D-coded

Pin	Pin assignment	Connector diagram
1	Transmit +	
2	Receive +	
3	Transmit -	
4	Receive -	

M12 circular plug, 4-pin - operating voltage

Pin	Wire colour ^{1.)}	Pin assignment
1	Brown	Operating voltage + 24 V DC
3	Blue	Operating voltage GND

1.) The wire colours indicated refer to the connection cable available as an accessory with the Article no. 918038.

Bürkert system bus (būS) connection



M12 circular plug x 1, 5-pin - būS connection

Pin	Wire colour	Pin assignment
1	CAN-Shield/Shielding	CAN-Shield/Shielding
2	Not assigned	
3	Black	GND/CAN_GND
4	White	CAN_H
5	Blue	CAN_L

M12 circular plug, 4-pin - operating voltage

Pin	Wire colour ^{1.)}	Pin assignment
1	Brown	Operating voltage + 24 V DC
2	Not assigned	
3	Blue	Operating voltage GND

1.) The wire colours indicated refer to the connection cable available as an accessory with the Article no. 918038.

5. Performance specifications

5.1. Signal flow diagram

Position control loop

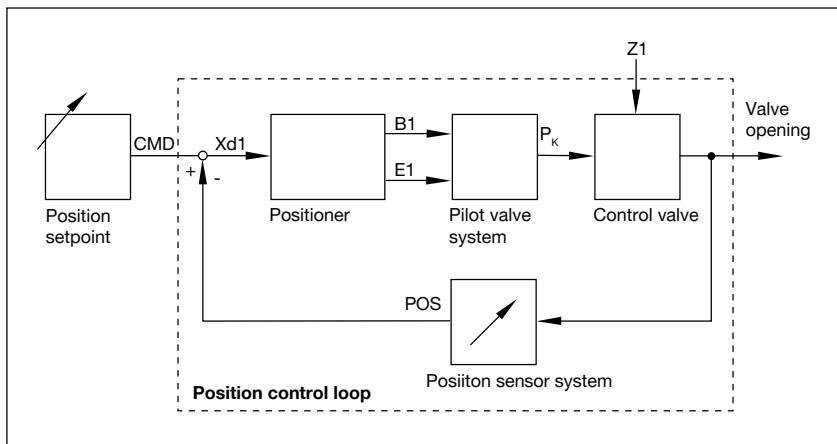

Additional software options of the TopControl Type 8692 (extract)

- Automatic commissioning of control system
- Automatic or manual characteristic curves selection
- Setting of the seal and the maximum stroke threshold respectively
- Parameterization of the positioner
- Limitation of the stroke range
- Limitation of the manipulating speed
- Setting of the moving direction
- Configuration of the binary input
- Signal range splitting on several controllers
- Configuration of an analogue or 2 binary outputs
- Signal fault detection
- Safety position
- Code protection
- Contrast inversion of the display
- Parameterizable diagnostic functions^{1.)}/Binary output (option)
 - Operating-hours counter
 - Path accumulator
 - Position monitoring
 - Graphical display of the dwell time density and movement range
 - Monitoring of the mechanical end positions in the armature
 - Direction reversal counter
 - Temperature monitoring

1.) Further diagnostic functions with detailed description can be found in the [operating instructions](#) ▶

5.2. Interface diagram

Version without fieldbus communication

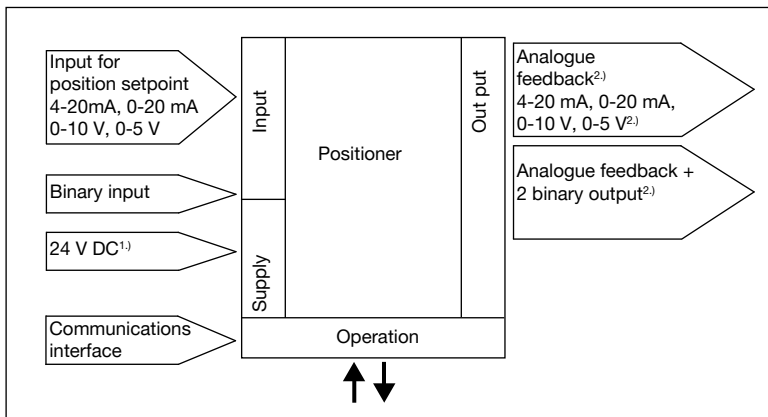

Version with fieldbus communication

With PROFIBUS DP, EtherNet/IP, PROFINET, Modbus TCP and Bürkert system bus (büS)

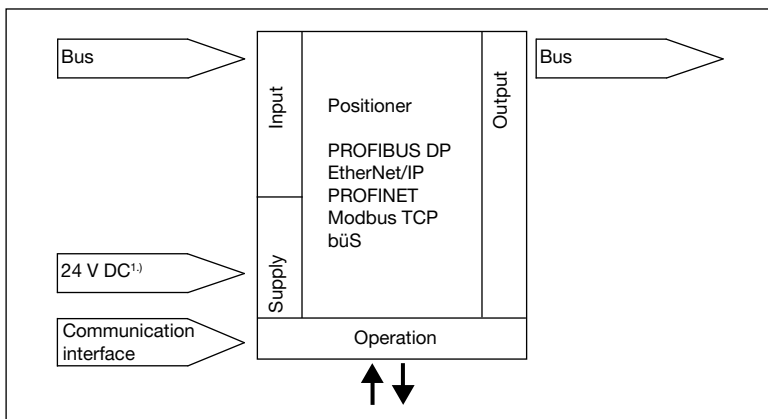

1.) The operating voltage is supplied with a 3-wire unit independent from the setpoint signal

2.) Alternative options

6. Product installation

6.1. Combination options with pneumatic process valves

Note:

A TopControl Control valve system consists of a **BASIC Positioner Type 8692** and an **ELEMENT control Type 23xx resp. 2103**

The following information is required to select a complete system:

- **Article no.** of the desired positioner TopControl **Type 8692**
- **Article no.** of the desired control valve **Type 23xx/2103** (see separate data sheets, **Type 2301** ▶, **Type 2300** ▶, **Type 2103** ▶)

You order two components and receive a completely assembled and tested valve.

Example for variations of the control valve system

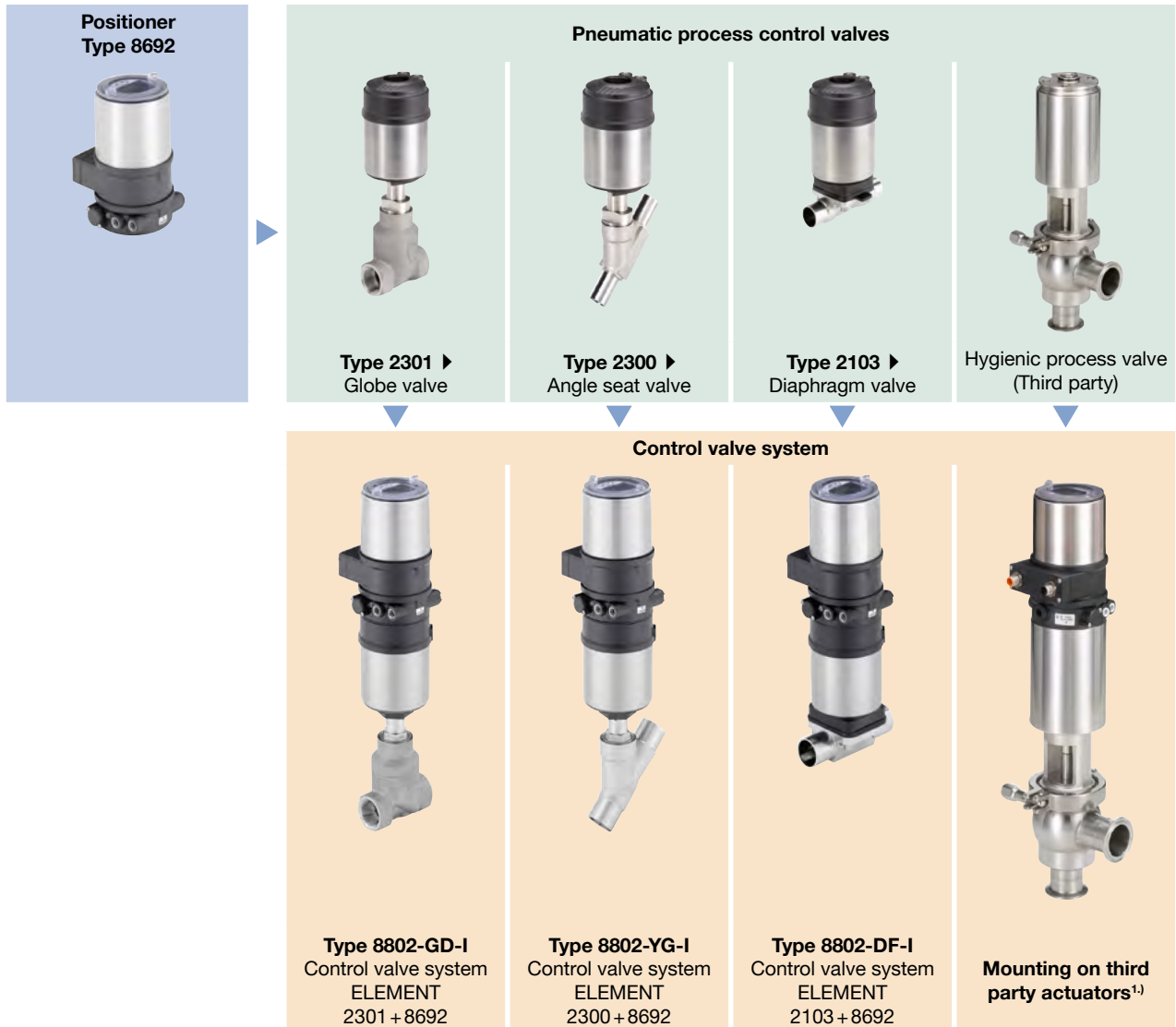

1.) See data sheet **adaptations for third-party drives, KK01** ▶ or contact the appropriate Bürkert sales office.

7. Ordering information

7.1. Bürkert eShop – Easy ordering and quick delivery



Bürkert eShop – Easy ordering and fast delivery

You want to find your desired Bürkert product or spare part quickly and order directly? Our online shop is available for you 24/7. Sign up and enjoy all the benefits.

[Order online now](#)

7.2. Bürkert product filter



Bürkert product filter – Get quickly to the right product

You want to select products comfortably based on your technical requirements? Use the Bürkert product filter and find suitable articles for your application quickly and easily.

[Try out our product filter](#)

7.3. Ordering chart

Note:

Standard versions are UL approved

Circuit function Pilot valve system	Communication	Electrical connection	Analogue feedback 0/4...20 mA	Analogue feedback 0/4...20 mA + 2 binary output	Diagnostic function ¹⁾	Bi-nary input	Pilot air ports threaded connection	Article no.	
								Standard	ATEX II Cat. 3G/ D, IECEx, CCC ²⁾
Actuator series Type 23xx, actuator size Ø 70/90 mm									
Low air capacity single-acting	Without fieldbus communication	Cable gland	-	-	-	Yes	G 1/8	306913	306982
			-	Yes	Yes	Yes	G 1/8	307005	306983
		M12 plug connector	-	-	-	Yes	G 1/8	307012	307095
			-	Yes	Yes	Yes	G 1/8	307123	307096
		PROFIBUS DP-V1	Via Bus	-	-	-	G 1/8	233348	265019
		EtherNet/IP	Via Bus	-	Yes	-	G 1/8	306849	306847
		PROFINET	Via Bus	-	Yes	-	G 1/8	306854	306851
		Modbus TCP	Via Bus	-	Yes	-	G 1/8	306859	306856
Bürkert system bus (bùS)	Via Bus	-	Yes	-	G 1/8	306863	306861		
Low air capacity double-acting	Without fieldbus communication	Cable gland	-	-	-	Yes	G 1/8	306905	306977
			-	Yes	Yes	Yes	G 1/8	307006	306978
		M12 plug connector	-	-	-	Yes	G 1/8	307124	307091
			-	Yes	Yes	Yes	G 1/8	307125	307092
		PROFIBUS DP-V1	Via Bus	-	-	-	G 1/8	265172	265004
		Actuator series Type 23xx, actuator size Ø 130 mm							
High air capacity single-acting	Without fieldbus communication	Cable gland	-	-	-	Yes	G 1/8	306922	306986
			-	Yes	Yes	Yes	G 1/8	307007	306987
		M12 plug connector	-	-	-	Yes	G 1/8	307084	307099
			-	Yes	Yes	Yes	G 1/8	307126	307100
		PROFIBUS DP-V1	Via Bus	-	-	-	G 1/8	233349	265033
		EtherNet/IP	Via Bus	-	Yes	-	G 1/8	306850	306848
		PROFINET	Via Bus	-	Yes	-	G 1/8	306855	306853
		Modbus TCP	Via Bus	-	Yes	-	G 1/8	306860	306857
Bürkert system bus (bùS)	Via Bus	-	Yes	-	G 1/8	306864	306862		
Actuator series Type 27xx, actuator size Ø 175/225 mm									
High air capacity single-acting	Without fieldbus communication	Cable gland	-	-	-	Yes	G 1/8	306925	306988
			-	Yes	Yes	Yes	G 1/8	306927	306989
		M12 plug connector	-	-	-	Yes	G 1/8	307041	307101
			-	Yes	Yes	Yes	G 1/8	307043	307102
		PROFIBUS DP-V1	Via Bus	-	-	-	G 1/8	233350	265041
		EtherNet/IP	Via Bus	-	Yes	-	G 1/8	313266	313265
		PROFINET	Via Bus	-	Yes	-	G 1/8	313269	313268
		Modbus TCP	Via Bus	-	Yes	-	G 1/8	313271	313270
Bürkert system bus (bùS)	Via Bus	-	Yes	-	G 1/8	313274	313272		

1.) See "Additional software options of the TopControl Type 8692 (extract)" on page 11











2.) CCC (China Compulsory Certificate) for device versions with Ex approval.

Further versions on request

➤	Additional EtherNet/IP, PROFINET, Modbus TCP and Bürkert system bus (bùS): double-acting versions with low air capacity
---	---

7.4. Ordering chart accessories

Standard Accessories



Description	Article no.
M12 socket, 8-pin with 5 m cable for input and output signals	919267 
M12 socket, 4-pin with 5 m cable for power supply	918038 
Silencer G 1/8	780779 
USB interface for serial communication (only for device versions with PROFIBUS, resp. analogue version with serial interface)	227093 
USB bÜS-Interface Set (bÜS Stick + connecting cable with M12 connector + connecting cable M12 to micro USB for bÜS service interface) for connecting to the PC tool Bürkert Communicator (only for device versions with EtherNet/IP, PROFINET, Modbus TCP Bürkert system bus (bÜS) resp. analogue version with service bÜS interface)	772551 
bÜS cable extension M12, length 1 m	772404 
bÜS cable extension M12, length 3 m	772405 
bÜS cable extension M12, length 5 m	772406 
bÜS cable extension M12, length 10 m	772407 
Sensor puck (spare part)	682240 
Software Bürkert Communicator	LINK 

Adapter kits

Note:

The accessories for adapter kits must be ordered separately

Adapter kits for third-party actuators can be found in the data sheet **Adaptation for third-party actuators, KK01**  or contact the appropriate Bürkert sales office.

Description	Actuator size	Control function	Article no.
Adapter kit for actuator series Type 23xx/2103	Ø 70/90/130 mm	Universal	679917 
Adapter kit for actuator series Type 27xx	Ø 175/225 mm	A (NO), B (NC)	679935 

Bürkert – Close to You

For up-to-date addresses
please visit us at
www.burkert.com

DTS 1000110876 EN Version: AB Status: RL (released | freigegeben | validé) printed: 25.05.2023

Austria
Belgium
Czech Republic
Denmark
Finland
France
Germany
Italy
Netherlands

Norway
Poland
Spain
Sweden
Switzerland
Turkey
United Kingdom

